

SME

MODEL 20/3

PRECISION TURNTABLE

Instructions

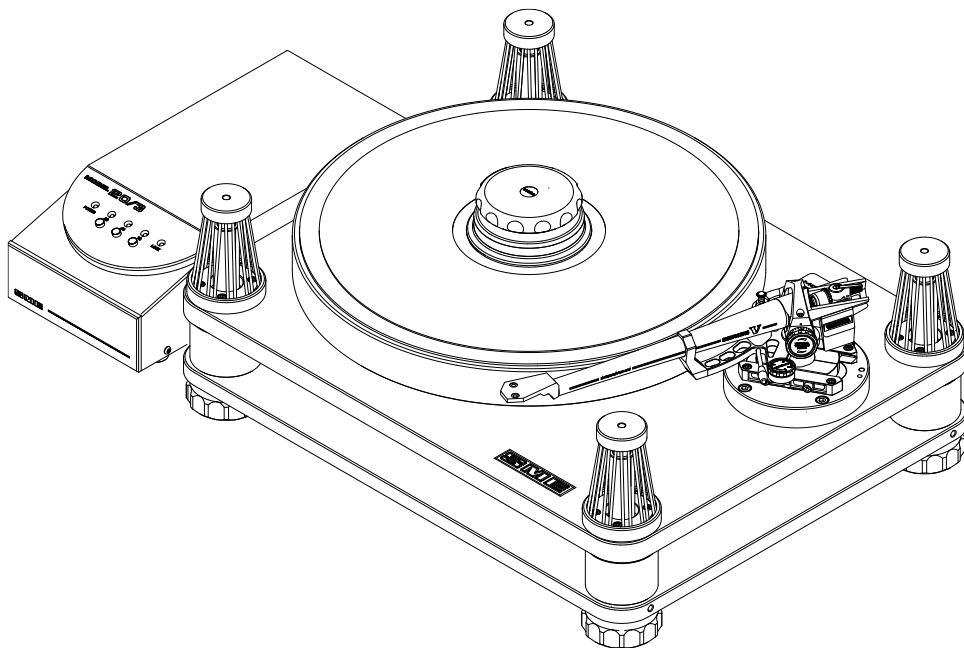

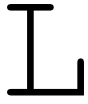

Warning! Important Safety Instructions

CAUTION:

RISK OF ELECTRIC SHOCK DO NOT REMOVE POWER SUPPLY UNIT COVER.

CAUTION: TO REDUCE THE RISK OF ELECTRIC SHOCK, DO NOT REMOVE THE POWER SUPPLY UNIT COVER. THERE ARE NO USER SERVICEABLE PARTS INSIDE. REFER ALL SERVICING TO QUALIFIED PERSONNEL.

- Please read this manual carefully and keep it in a safe place for future reference.
- The slots in the Power supply unit at the back and underside are provided for necessary ventilation. To ensure reliable operation of this apparatus, and protect from overheating, these slots must never be blocked or covered.
- Do not place a water containing vessel on this apparatus, as this can result in a risk of fire or electric shock. Do not expose this apparatus to rain or place it near water.
- If this apparatus accidentally gets wet, unplug it and contact an authorized dealer immediately.
- You can clean this apparatus with a damp cloth when necessary, but be sure to unplug the apparatus first. To cut off the power source, unplug the apparatus from the wall outlet.
- Do not overload wall outlets, extension cords or adaptors beyond their capacity, since this can result in fire or electric shock.
- Power supply cords should be routed so that they are not likely to be walked on or pinched by items placed upon or against them, paying particular attention to cords at the plug end, adaptors and the point they exit from the appliance.
- Before connecting the AC power cord to the Power supply unit, make sure the voltage of the Power supply unit, as marked on the label at the rear, corresponds to the local electricity supply.
- Never insert anything metallic into the open parts of this apparatus.
- Only a qualified technician should remove the Power supply unit cover.
- Be sure to hold the plug, not the cord, when disconnecting this apparatus from an electric socket.
- Locate this apparatus near an easily accessible AC outlet.
- If this apparatus does not operate normally, in particular if there are any unusual sounds or smells, unplug it immediately and consult an authorized dealer.
- Unplug this apparatus from the AC outlet before any service.

IMPORTANT NOTICE:

The mains lead on this equipment when supplied for use in the UK, is fitted with a moulded plug incorporating a fuse. The value of the fuse is indicated on the pin face of the plug and if it required replacing a fuse approved to BSI 1362 of the same rating must be used. Never use the plug with the fuse cover omitted if the cover is detachable. If the plug fitted is not suitable for the power points in your house or the cable is not long enough to reach the power point, you should obtain a suitable safety approved extension lead or consult your dealer for assistance. However, if there is no alternative but to cut off the plug, remove the fuse first and then safely dispose of the plug. DO NOT connect the plug to a mains socket as there is a risk of shock hazard from the bared flexible cord.

IMPORTANT:

The wires in the mains lead are coloured in accordance with the following code: **BLUE NEUTRAL, BROWN LIVE**. As these colours may not correspond to the coloured markings identifying the terminals in your plug, proceed as follows: The wire coloured BLUE must be connected to the terminal marked with the letter N or coloured Blue or BLACK. The wire coloured BROWN must be connected to the terminal marked with the letter L or coloured BROWN or RED.

WARNING:

DO NOT CONNECT EITHER WIRE TO THE EARTH TERMINAL, WHICH IS MARKED WITH THE LETTER E OR BY THE EARTH SYMBOL , OR COLOURED GREEN OR GREEN AND YELLOW.



WEEE SYMBOL INFORMATION

Correct Disposal of This Product (Waste Electrical & Electronic Equipment)

(Applicable to the European Union and other European countries with separate collection system).

The marking shown on this product or its literature, indicates that it should not be disposed with other household wastes at the end of its working life. To prevent possible damage to the environment or human health from uncontrolled waste disposal, please separate this from other types of wastes and recycle it responsibly to promote the sustainable re-use of material resources.

Household users should contact either the retailer where they purchased this product or their local government office, for more detailed information of where and how they can take this item for environmentally safe recycling.

Business users should contact their supplier and check the terms and conditions of the purchase contract. This product should not be mixed with other commercial wastes for disposal.

SME

MODEL 20/3

PRECISION TURNTABLE

Instructions

This is no ordinary turntable. These instructions have been compiled covering unpacking, adjustment and installation procedures. Please read carefully as you proceed.

1. INTRODUCTION

The SME Model 20/3 Precision Turntable is built to the same engineering standards and incorporates many of the design features originated for the Model 30. This splendid turntable offers total reliability and freedom from critical adjustments whilst massive construction and vibration free moving parts ensure wide-band sound of exceptional detail, resolution and dynamic range.

2. CONTENTS

Page	
4	Introduction
6	Dimensions and specification
7	Packing list
8	Parts identification
9	Unpacking
10/11	Setting up
11	Operation - Turntable speed adjustment
12	Operation
12/13	Maintenance
13	Transit precautions
14	Guarantee
15	Appendix

3. DIMENSIONS

Width	440.0mm (17.32")
Depth	350.0mm (13.78")
Height	173.5mm (6.83")
Platter Diameter	325.0mm (12.80")
Spindle to Arm	215.4mm (8.48")
Net Weight	31.0Kg
Shipping weight	45.0Kg

4. SPECIFICATION

The turntable is driven by a 3-phase, 6 pulse, inductance motor, with 8 pole Neodymium magnets and 3 integrated Hall position sensors.

The electronic controller uses a high performance microcomputer, optimised for motor control. The Hall position sensors on the motor provide accurate feedback to the micro controller allowing very accurate and stable speed control, including 33 1/3, 45 and 78 rpm. The reference oscillator is a 10MHz quartz crystal, which is multiplied by 4 to produce an internal microprocessor clock speed of 40MHz.

The driver stage has CMOS buffers/MOSFET drivers with 1.2 Amp peak drive capability.

The power output stage is six high power complimentary Mosfets in a 3 Phase Bridge Driver configuration.

Closed loop speed control is implemented using a pseudo sine wave commutation sequence and a proportional-plus-integral (PI) algorithm.

The design incorporates a 4 layer surface mount technology pcb with on-board user adjustable speed variation control.

5. SPEED RANGES

33 1/3, 45 and 78 rpm.

6. PACKING LIST

Qty		Part No.
1	Model 20/3 base and sub-chassis assembly	1119-20/3
2	Suspension Bands (spares)	1020
1	Syringe of Spindle Oil	1058/20
1	4mm A/F Hexagon Wrench	1083
1	Stroboscopic Disc	1087
1	Control Unit	1081
1	Power Cord	1098-9
1	Drive Belt	1100
1	Syringe of Lubricating Oil	1287
1	Platter	1120-12
1	Oil Filler Adaptor	1129
1	Record Spindle Washer	1148
1	Soft Cover	1160-20/3
1	Operating Instructions	1164-20/3
1	Height Setting Gauge	1165
1	Reflex Record Clamp	1239
1	Box Spanner	1946
4	M3 x 12 Socket Cap Screws	5893/12
1	2.5mm A/F Hexagon Wrench	5896
1	3mm A/F Ball-ended Hexagon Wrench	5905
1	2.0mm A/F Hexagon Wrench	5924

7. PARTS IDENTIFICATION

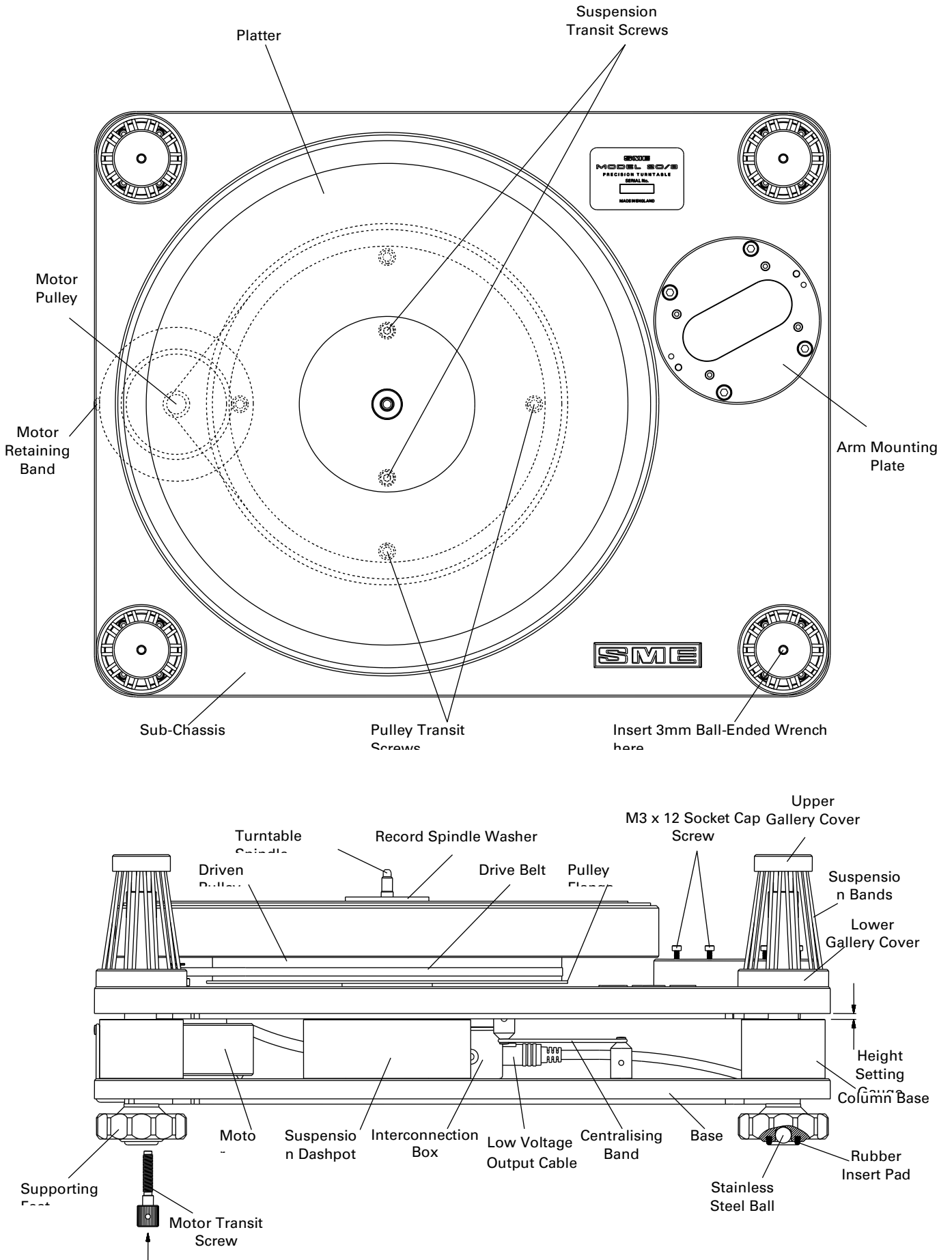

8. UNPACKING

1. Unpack and check all items against the packing list on Page 7. Any missing parts should be reported to your dealer at once.
2. The turntable should be placed on a substantial table or steel equipment stand, this should be in its final position for setting up, as movement after this procedure is best avoided.
3. The levelling feet allow for two methods of interface with the mounting surface.
 - a) As received on rubber insert pads set into the underside of the feet.
 - b) Stainless steel balls also set into the underside of the feet.

WARNING:

Method (b) is not suitable for delicate surfaces as indentation may be caused.

4. If hard mounting the turntable on the stainless steel balls is preferred, proceed as follows:
 - a) Position the base so that one end overhangs the table by about 10cms, unscrew and remove both of the exposed feet.
 - b) Remove the rubber pad from the foot by pushing out through the small hole on the upper side of the foot using the longer leg of the 2mm A/F hexagon wrench.
 - c) Replace the turntable feet and repeat the procedure for the two feet at the opposite end of the unit.
5. Lift the left hand end of the turntable and remove the Motor Transit Screw from the underside of the base immediately below the motor. Remove the Motor Retaining Band. Remove the two packing strips from beneath the motor and relocate the three motor feet in the dimpled mountings. Refit the Motor Retaining Band.
6. The turntable is packed with only a little oil in the bearing housing and this should now be filled. A metered charge is provided in Syringe Part No: 1058/20.

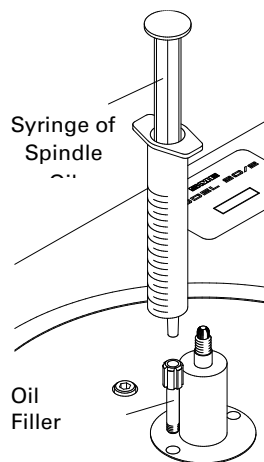

7. Remove the syringe from its packing and insert the tip into the Oil Filler Adaptor, which will be found already fitted to near the spindle. (as illustration left).
8. Slowly inject the complete quantity into the bearing maintaining downward pressure throughout the operation to prevent leakage.
9. Remove the syringe and dispose of it responsibly!
10. Unscrew and remove the Oil Filler Adaptor using the Box Spanner Part No: 1946. Retain the adaptor for possible future use
11. The suspension is also secured for transit and the two screws are accessible through holes in the driven pulley (see page 8, suspension transit screws). Hold the sub-chassis down and remove these screws with their sleeves using the 4mm A/F hexagon wrench, allow the chassis to rise under the natural pull of the suspension.

9. SETTING UP

1. For transit the main bearing is off-loaded by four pulley transit screws. These are captive and should be turned anti-clockwise with the 3mm A/F ball-ended hexagon wrench until they stop. Ensure the wrench is fully engaged to avoid damage to the transit screw socket.
2. Unpack the drive belt and place it over the driven pulley. Press it down as far as the flange, ensuring that it is free from twists, then stretch it over the motor pulley. The pulleys will be out of alignment without the weight of the platter so rotation must not take place until it has been fitted.
3. Now fit the platter. Place it carefully and squarely over the turntable spindle and lower it gently down until it rests on the driven pulley, having first ensured that both mating surfaces are clean. Rotate the platter slowly by hand to position the belt on the pulleys. *WARNING:* Please avoid handling or anything that might scratch the turntable platter. The material is as delicate as a record itself and very easily damaged.
4. The base should now be levelled by rotating the supporting feet. The feet will turn more readily if the corresponding corner of the base is lifted slightly at the same time.
5. The Model 20/3 is intended to receive SME precision pick-up arms such as the Series V, Series IV or Series 300 Model 309.
6. If you are not already familiar with SME precision pick-up arms, carefully study the instruction book at this point. Fit the cartridge of your choice. Ensure that the four socket cap screws holding the arm mounting plinth to the sub-chassis are tight. The arm should now be secured to the plinth using the four M3 x 12mm socket cap screws already in it. Rotate the output socket on the underside of the arm so that it lies parallel with the right hand side of the base and its mouth facing the front. Plug in the audio lead arranging it to clear the base. Two cable clamps are provided on the underside of the sub-chassis to secure the audio lead and allow it to exit either to the rear or the right hand side of the turntable.
7. The upper gallery cover at the top of each of the four columns has a small central hole. To adjust the height of the sub-chassis insert the 3mm A/F ball-ended hexagon wrench engaging the socket within. Clockwise rotation will then raise the sub-chassis and the reverse will lower it.
8. Adjust the sub-chassis suspension at each point so that the Height Setting Gauge (1165) will enter easily between the points indicated on page 7. This will set the gap at 3mm, if it is desired to increase sub-chassis isolation because of unusually close proximity to the speakers the recommended gap can be exceeded by up to 2mm. After adjustment hold the sub-chassis fully down, then release it. Check and readjust as needed, noting that new suspension bands take a little while to settle down. A single band arranged horizontally beneath the sub-chassis centralises it against the pull of the driving belt.
9. Rotate the platter slowly by hand to ensure that the drive belt takes up a central position on the crown of the motor pulley.
10. Unpack the power supply unit, the mains voltage setting is indicated on the back panel. Before fitting the power cord check carefully that this matches your mains voltage.
11. The power cord has a standard moulded mains plug. In the event that it must be replaced the original plug should be cut off and disposed of responsibly.
12. **WARNING!** To meet international safety standards the power supply unit is earthed through the yellow/green wire of the power cord and particular care must be taken to ensure that this is connected so as to maintain effective earthing should the original mains

plug be changed.

13. Connect the low voltage output cable from the control unit to the turntable by inserting the DIN plug into the socket at the end of the interconnection box mounted at the rear of the turntable base. *NOTE:* It is essential that this plug is fully inserted to ensure complete electrical engagement. It may be found helpful if the turntable platter is removed to increase the between chassis space available for this task. Ensure that this and any other leads are dressed clear of the suspension columns. Re-check that the mains voltage indicated on the back panel of the power supply unit matches your mains voltage. Plug the power cord into the power supply unit and the mains supply. An on-off switch is situated on the back of the control unit immediately above the mains socket.

10. OPERATION - Turntable speed adjustment

The Model 20/3 precision turntable is partly run-in before leaving the factory but will further benefit from the first few weeks of use.

If you should wish to check the speed settings and make your own adjustment, the procedure is as follows:

1. Complete the Setting Up procedure as detailed in Section 8 above and the arm and cartridge set-up procedures detailed in the Series V instruction book.
2. Plug the Power Supply in and switch ON, the mains switch is at the rear. The LED marked POWER will light up.
3. Place the Stroboscopic Disc (1087) on the platter. Use the bands appropriate for your mains AC frequency. Re-check the drive belt for centrality on the motor pulley.
4. Press button 33 once to start the turntable platter rotating, the LOCK LED blinks until the speed stabilises (for up to 25 seconds) and then becomes constant indicating that the selected speed is locked.
5. To adjust speeds depress and hold down the 33 and 45 buttons together for 8 to 10 seconds the 33 LED will flash after this period indicating that the adjustment mode is engaged; release both buttons. Press and release the 33 button to 'slow down' or the 45 button to 'speed up'. The disc should be viewed in a fluorescent or neon light. The appropriate band will synchronise and appear stationary when the speed is correct, whilst clockwise and reverse movement will indicate fast or slow running respectively. This is best observed if the pick-up arm, with cartridge fitted and in the raised position, is placed directly over the band being viewed as a reference point. The adjustment method provides a microfine increment for each press of the button, so a number of depressions will have to be made to make an appreciable difference to the turntable speed. When the speed adjustment is completed depress and hold down the 33 and 45 buttons together for 5 seconds, the 33 LED will stop flashing and become constant and your speed setting will be stored in the system memory for future use.
6. Repeat this process for the 45 and 78 speed ranges if required.

11. OPERATION

1. Place the record spindle washer on the spindle followed by the record and clamp. The latter should be screwed down clockwise enough to deflect the record flat into firm contact with the platter. With a fingertip tap the record in three places equally over its surface and with a little practice it will soon become evident whether or not the record is touching the platter. If not, some further tightening may be necessary but this is not always the answer however and sometimes releasing the clamp a little may do more to effect the desired improvement.

The foregoing clamping instructions assume vinyl records, for shellac 78's the record washer should not be used for risk of breaking the record.

2. The turntable is now ready for use. At this point packing and other items that are no longer required should be stored in the case so as to be available if needed in the future.
3. The Model 20/3 is not equipped with a lid as this would increase the likelihood of acoustic feedback. A soft cover is provided to protect the turntable from dust when not in use. The back should be fitted first and the cover then brought forward so that the front can be guided safely past the cartridge and stylus. When removing the cover start at the back and lift it upwards then forwards away from the front of the tone arm.

12. MAINTENANCE

1. There are no critical adjustments or need for 'tweak' and only very little maintenance. Clean the drive belt occasionally by drawing it through a piece of soft tissue or linen moistened with lighter fuel. The same material may be used to clean the periphery of the motor and driven pulleys. The main bearing is lubricated for life.
2. Having sintered bronze bearings the motor requires minimal lubrication. One drop of oil only in one year is sufficient and should not be exceeded. Remove the platter and drive belt. Apply one drop of 1287 oil from the syringe at the point indicated on top of the motor. Choose a time when the turntable will not be used for some hours so that the oil can find its way down to the lower bearing. After this time check that there is no oil on the motor pulley and replace the drive belt and platter. For cleaning, the platter should be removed from the turntable whilst its surface is sponged with a soft cloth using warm water and washing-up liquid, followed by warm water only then a dry towel.
3. The suspension dashpot is automatically sealed when the sub-chassis is locked down and does not require maintenance.
4. Replace the drive belt after 1000 hours use. A replacement (Part No. 1100) is available from SME Limited.
5. The life of the suspension bands will depend on climatic conditions. If eventually they should stretch beyond further adjustment, replacements (Part No. 1020) are available from SME Limited.
6. Changing the bands is simple and may even be done while a record is playing! Two spare bands are provided in case of accidental damage. Unscrew and remove the upper gallery cover from the top of the column and lift off the lower gallery cover. Remove the old band and replace the new one over the anchorage studs. Replace the covers and re-check the suspension height with the gauge.
7. The motor retaining and centralising bands will last indefinitely, however should one become dislodged or lost, during unpacking for example, it must be refitted before the turntable is used. The bands are located on anchor studs and fitted as shown in the illustration on page 8, replacements (Part No. 1020) are available as paragraph 4 above.
8. There are no user-serviceable parts inside the control unit. A 500 milli-amp fuse is located below the mains socket, its replacement should only be undertaken by qualified service personnel.

13. TRANSIT PRECAUTIONS

The Model 20/3 can be safely transported,

SUBJECT ABSOLUTELY TO THE FOLLOWING PRECAUTIONS:

Short journeys by car: remove the platter, disengage the drive belt from the motor pulley, and replace the two packing strips beneath the motor and secure with the motor transit screw. Lock down the suspension. Screw down the four driven pulley transit screws not more than one turn, just enough to prevent the pulley rotating freely. The turntable itself is best placed on the floor of the car in front of the passenger seat. The platter and other items can be stowed elsewhere provided they are carefully protected. For all other transportation purposes the original packing case and materials must be used.

GUARANTEE

Your SME Model 20/3 precision turntable is guaranteed against faulty material and workmanship. The nominal period of the guarantee is twelve months but is liberally interpreted at our discretion subject to the following conditions being observed:

1. Any matter arising must in the first instance be raised with SME Limited at the address appearing below.
2. In no circumstances return the turntable or any part thereof to SME Limited unless we have requested you to do so. Responsibility will not be accepted for any items or costs arising if this point is disregarded.
3. Items returned to our Service Department must be:
 - a) Sent strictly in accordance with the packing and routing directions which we will provide.
 - b) Insurance should be effected by the owner. SME Limited is unable to accept liability for any items until they reach the factory safely.
4. Defective parts will be replaced free of charge. The cost of labour may be charged at the discretion of SME Limited. Return transport and insurance costs will be charged.
5. The guarantee expressly excludes:
 - a) Damage by any cause whatever.
 - b) Contingent and third party liability.
 - c) Personal injury.
6. No alteration or variation of the guarantee will be recognised by SME Limited.
7. The guarantee is not transferable.

SME Limited · Steyning · Sussex · BN44 3GY · England

Tel: +44 (0)1903 814321 · Fax: +44 (0)1903 814269

e-mail: service@sme.ltd.uk

www.sme.ltd.uk

15. APPENDIX

We hope these instructions have made the installation of your Model 20/3 precision turntable straightforward. Care for it as befits its fine construction. Do not invert it. Do not apply oil or other lubricant except as directed. Do not attempt to take it to pieces or interfere with any of the screws except as directed in the instructions. To do so will invalidate the warranty and may occasion costly repairs. Keep your turntable clean by dusting it regularly with due regard for the safety of the cartridge and stylus. Always use the soft dust cover when not in use. Finger marks may be removed from the black enamel/chrome finish with a linen handkerchief moistened with lighter fuel. Do not use any other kind of spirit or solvent cleaner.

In the unlikely event of a problem concerning operation or service, always contact us in the first instance at the address on page 14, stating the exact nature of the problem, the name and address of the dealer who supplied the unit and its serial number which will be found on the label at the rear of the arm mounting plinth.

SME