

Q U A D 306 Power Amplifier Service Data

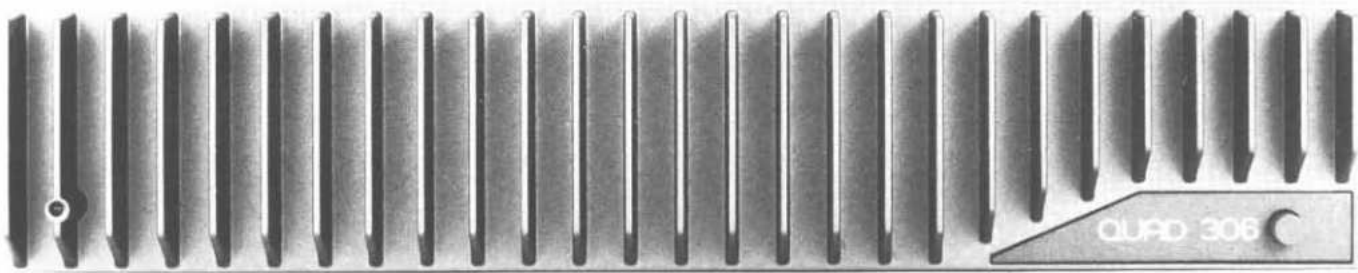

Q U A D 306 service data

CONTENTS

	Page
Description	3
Specifications	4
Front and Back Views.....	5
Dismantling for Service	6
Mains Volt Changes – Replacing Mains Transformer	6
Amplifier Performance Testing	8
Modifications.....	10
Service Notes	10
Exploded View.....	12
Parts List	13
PCB Layouts: issue 2 PCB	20
issue 3 PCB	22
Circuit Diagrams: issue 2 PCB	21
issue 3 PCB	23

Q U A D 306 service data

DESCRIPTION

The Quad 306 is a two channel power amplifier primarily intended for use in high quality sound reproducing systems. The amplifier is usually used with a Quad control unit though other signal sources can readily be accommodated.

The amplifier uses a current dumping output circuit, a Quad invention which eliminates many of the problems associated with transistor amplifiers, and covered by patents in several countries. In a current dumping amplifier there is in effect both a low power very high quality amplifier and a high power heavy duty current dumping amplifier. The low power amplifier controls the loudspeakers at all times, calling upon the high power section to provide most of the muscle. The small amplifier is so arranged – it carries an error signal – that provided the larger power transistors (the dumpers) get within the target area of the required output current it will fill in the remainder accurately and completely. The reproduced quality is *solely* dependent on the small amplifier which because of its low power can be made very good indeed.

Problems of crossover distortion, quiescent current adjustment, thermal tracking, transistor matching, all disappear. There are no internal adjustments or alignments and the choice of power transistor types is less restrictive.

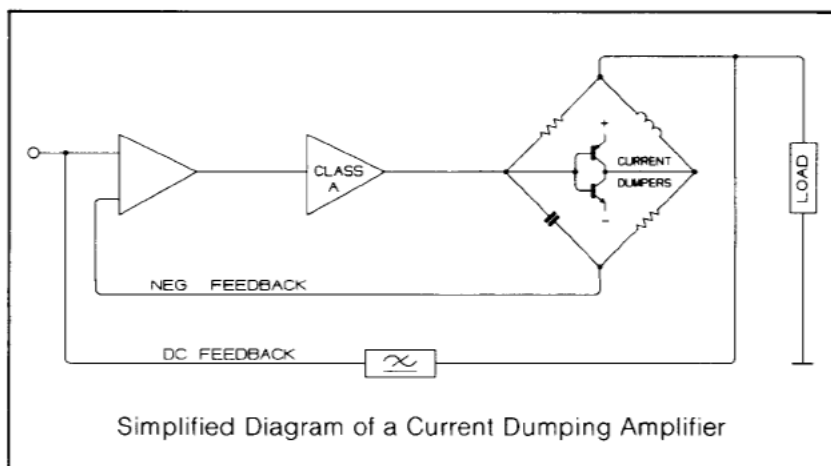

QUAD 306 service data

SPECIFICATIONS

Measurements apply to either channel. All measurements made at 230V AC.

POWER OUTPUT:

See graph.

DISTORTION:

Continuous sine wave into 8Ω resistive load
20Hz any level up to 50 watts < 0.01% Dtot
1kHz any level up to 50 watts < 0.01% Dtot
20kHz any level up to 50 watts < 0.03% Dtot

OUTPUT INTERNAL IMPEDANCE AND OFFSET:

$1.5\mu\text{H}$ in series with 0.05Ω . Offset typically 7mV.

FREQUENCY RESPONSE:

Ref. 1kHz -0.25dB at 20Hz and 20kHz
-1.0dB at 13Hz and 40kHz

POWER RESPONSE:

Ref. 1kHz -0.25dB at 20Hz and 20kHz

SIGNAL INPUT LEVEL:

0.375 volts for 50 watts into 8Ω
Amplifier loads the input by $20\text{k}\Omega$

SIGNAL INPUT OVERLOAD:

Instantaneous recovery up to +15dB overload.

CROSSTALK:

Input loaded by $1\text{k}\Omega$
100dB at 100Hz
85dB at 1kHz
65dB at 10kHz

HUM AND NOISE:

(15.75kHz measurement bandwidth)
Unweighted -105dB ref. 50 watts.

STABILITY:

Unconditionally stable with any load and any signal.

AC INPUT:

110-120V or 220-240V, 30-250 watts, depending on signal level.

WEIGHT:

4.62Kg.

DIMENSIONS:

321mm wide, 64mm high, 207mm deep.

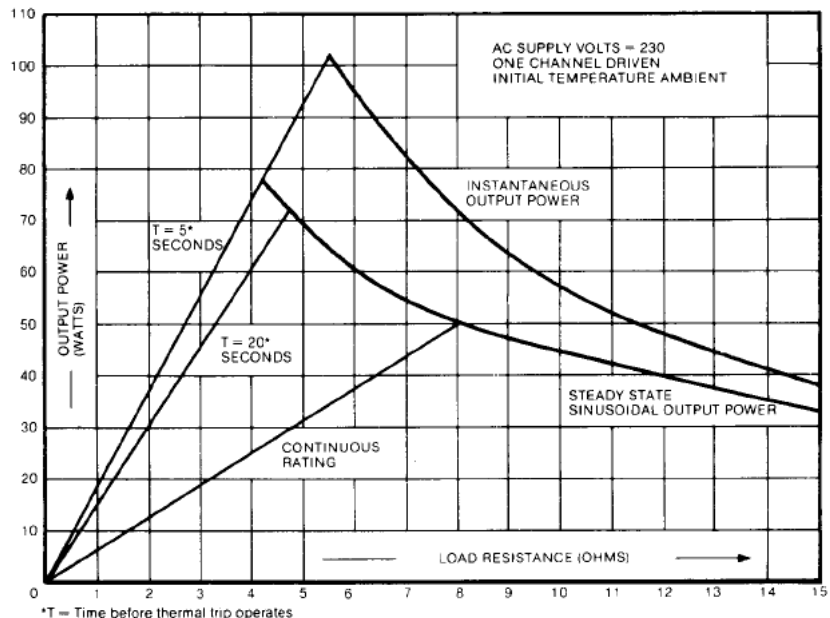

Q U A D 306 service data

FRONT VIEW

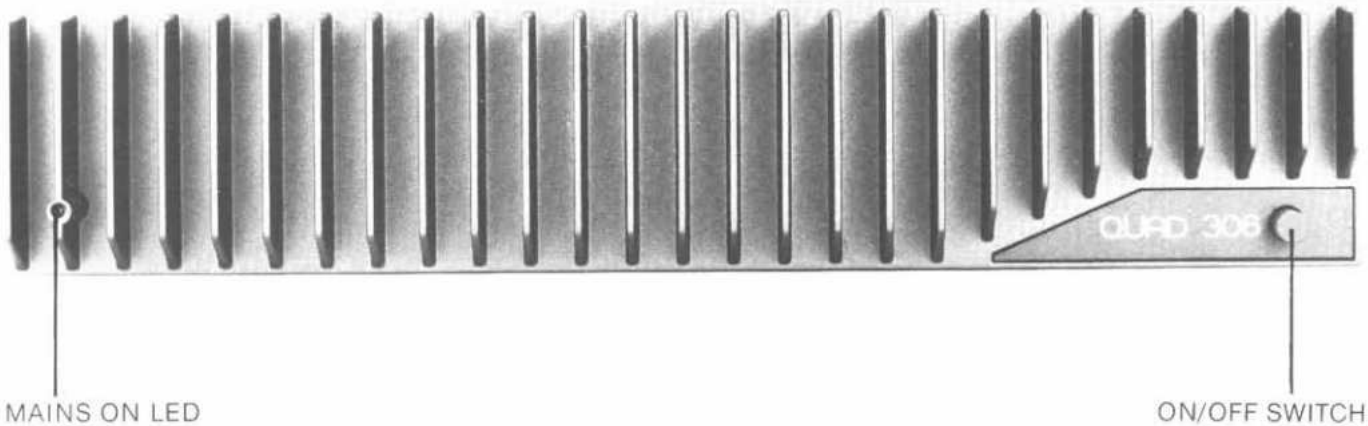

BACK VIEW

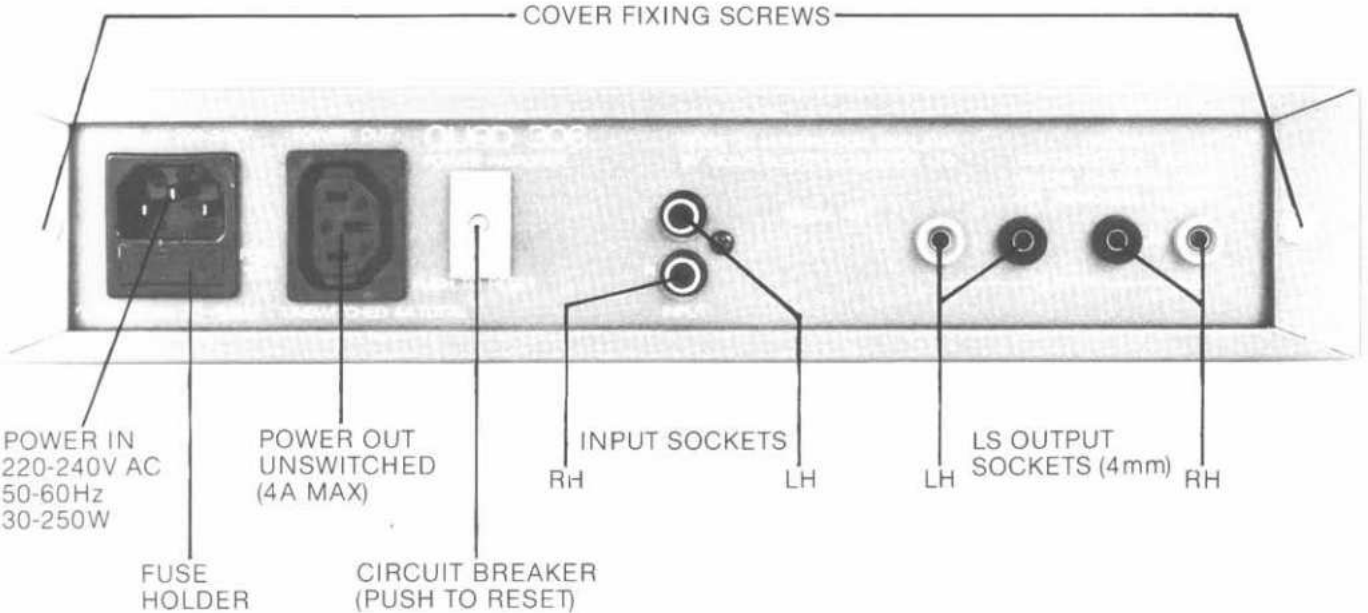

Q U A D 306 service data

DISMANTLING FOR SERVICE

- (a) Disconnect from mains supply.
- (b) Remove two screws in rear of case.
- (c) Gently slide off cover assembly. This will allow access to all the major components.
If necessary, the plastic protection cover for the mains supply section of the printed circuit board can be removed by gently prising out the retaining stud or pressing the stud out from the top of the printed circuit board.
- (d) Re-assemble in reverse order – DO NOT forget to replace the plastic protection cover over the printed circuit board mains section.

MAINS VOLTAGE CHANGES – REPLACING MAINS TRANSFORMER

The 306 is normally supplied for 220/240V 50Hz AC operation. For other voltage supplies the mains transformer (L4), the circuit breaker (N1) and the mains fuse (FS1) must be replaced with the correct type as shown in the following list.

Voltage Range		Transformer (L4)	Circuit Breaker (N1)	Fuse (FS1)
220-240V	rating part no.	220-240V 50-60Hz L20571A	0.5A SP306AA	2AT UM02ADA
110-120V	rating part no.	110-120V 50-60Hz L12905A	1A SP306AB	3.15AT UM3A15D
120V CSA	rating part no.	120V 60Hz L12905C	1A SP306AB	3AT CSA UM03ADC
100V Japan	rating part no.	100V 50Hz L12916A	1.5A SP306AJ	3.15 AT UM3A15D

NOTE: Additional minor changes may be required in some countries depending on local regulations.

Q U A D 306 service data

PROCEDURE

- (a) Dismantle as shown under 'Dismantling for Service'.
- (b) Unsolder the seven transformer connecting wires – note the colours and connections.
- (c) Remove single centre fixing screw whilst supporting transformer, to avoid damaging other components.
- (d) Gently lift out transformer – should the insulating washer be stuck, prise off carefully and remove damaged washer pieces from printed circuit board before fitting replacement transformer.
- (e) Fit new transformer. Ensure isolating washer is fitted and transformer is firmly tightened down to prevent movement.
- (f) Reconnect wires observing colour code shown below.

Voltage	Transformer ref.	Code	Primary	Part Number
220-240V	5B473P*	Red Spot	Orange/Black	L12904A
220-240V	VT30544	Red Spot	Orange/Orange	L20571A
110-120V	5B595P	Yellow Spot	Orange/Brown	L12905A
120V CSA	5B800P	Blue Spot	Orange/Brown	L12905C
100V Japan	5B596P	Green Spot	Pink/Brown	L12916A

Secondaries: (1) Red/Yellow
(2) Blue/Grey
(Earth) Green with yellow stripe

*early models only

- (g) Replace circuit breaker and fuse with correct type.
- (h) Re-assemble in reverse order.

IMPORTANT

Ensure 306 is clearly labelled to show voltage range and country of use.

QUAD 306 service data

AMPLIFIER PERFORMANCE TESTING

TEST EQUIPMENT REQUIREMENTS:

- (1) Oscilloscope
- (2) Distortion analyser
- (3) AF signal generator sine/square
- (4) Audio millivoltmeter
- (5) Multimeter
- (6) Dummy loads. 8 Ω (50W), 4 Ω (75W), 1.414 Ω (30W), 1 Ω (25W)

(a) AC QUIESCENT CURRENT:

Test under no signal conditions.

240V Typically 60mA

120V Typically 120mA

(b) DC SUPPLY:

Test under no signal conditions. +ve and -ve supply rails to be approximately 36-41V DC.

(c) INPUT SENSITIVITY:

With dummy 8 Ω load connected, drive LH channel at 1 kHz for 50W output (20V). Input to be $0.375V \pm 0.5dB$. Increase input and ensure no instability appears at clipping point. Repeat for RH channel.

(d) DISTORTION:

With dummy 8 Ω load connected drive LH channel for 50W output (20V). Distortion to be as shown for the following frequencies. Repeat for RH channel.

100Hz < 0.01%

1kHz < 0.01%

3kHz < 0.01%

10kHz < 0.03%

20kHz < 0.03%

(e) LOW OUTPUT DISTORTION:

With dummy 8 Ω loads connected, check LH and RH channels at 1 kHz and 1W output (2.828V) check for clean undistorted waveform with no sign of instability.

(f) SQUARE WAVE PERFORMANCE:

With dummy 8 Ω loads connected, drive RH and LH channels with 3kHz squarewave at approximately 200mV, vary input level but avoid clipping. Check for clean waveform. Remove loads and check for overshoot.

(g) FREQUENCY RESPONSE:

With dummy 8 Ω load connected drive LH channel at 1 kHz for 50W output (20V). Response should be within limits shown below. Repeat for RH channel.

10Hz -2.5dB

20Hz -0.25dB

20kHz -0.25dB

Q U A D 306 service data

(h) SIGNAL/NOISE RATIO:

With dummy 8Ω load connected, drive LH channel at 1 kHz for 50W output (20V). Remove drive and short circuit input. Unweighted signal/noise ratio should be better than -105dB (15.75kHz measurement bandwidth -6dB per octave roll-off above 10kHz). Repeat for RH channel. 'A' weighting will give approximately 6dB improvement.

(i) CROSSTALK:

With dummy 8Ω loads connected drive LH channel at 1 kHz for 50W output (20V). Terminate input of RH channel with 1k ohm and measure crosstalk at RH channel output, to be better than 85dB. Repeat for RH channel driven and output at LH channel measured.

(j) OUTPUT AT 4 Ω :

With dummy 4Ω load connected drive LH channel at 1 kHz just prior to clipping – output to be approximately 70W (16.73V) depending on temperature. Distortion < 0.01%.

Repeat for RH channel.

(k) CURRENT OUTPUT DRIVE:

With dummy 1.414Ω load connected drive LH channel at 1 kHz and observe output on oscilloscope. The rms voltage measured just prior to clipping will equal the peak current in amps – nominally 6.5A.

Alternatively, if 1.414Ω resistors are not available use 1Ω resistors where an output of 4.6V rms equals a peak current of 6.5A.

Repeat for RH channel.

The circuit breaker will operate within approximately 4 seconds when hot and approximately 9 seconds when cold.

Q U A D 306 service data

MODIFICATIONS

- | | |
|--------------------------------|---------------------------------------------------------------------------------------------------|
| (1) FEB. 86 (S/No 1000 APPROX) | R27 increased from 6k8 Ω to 12k Ω . To reduce brightness of "mains-on" LED. |
| (2) NOV. 86 (S/No 4000 APPROX) | R11 (47 Ω) moves to junction of R15/R16 and +ve of C5 – to improve stability on clipping. |
| (3) FEB. 87 (S/No 5500 APPROX) | Printed circuit board issue 3 introduced incorporating R34, R35 and D13. |

SERVICE NOTES

- (a) The pink paint spots on the output transistors (17556) are temperature sensitive and will change to purple at approximately 115°C. This indicates poor thermal conduction to heatsink or over-running.
- (b) When replacing driver and output transistors it is imperative that new thermal conduction 'Sil' pads are fitted (Do not use old pads). Also the 'Belleville' copper finish washers and heatsink washers must be replaced. Should the heatsink and transistor mounting bracket be separated these must be firmly reseated with heat conductive silicon paste.
- (c) The centre tapped DC Line (+40V -40V) is floating and some faults may cause this to shift putting up to 80V on one side possibly damaging R30/R31 (2k2 Ω). These components should always be checked during repair.

Q U A D 306 service data

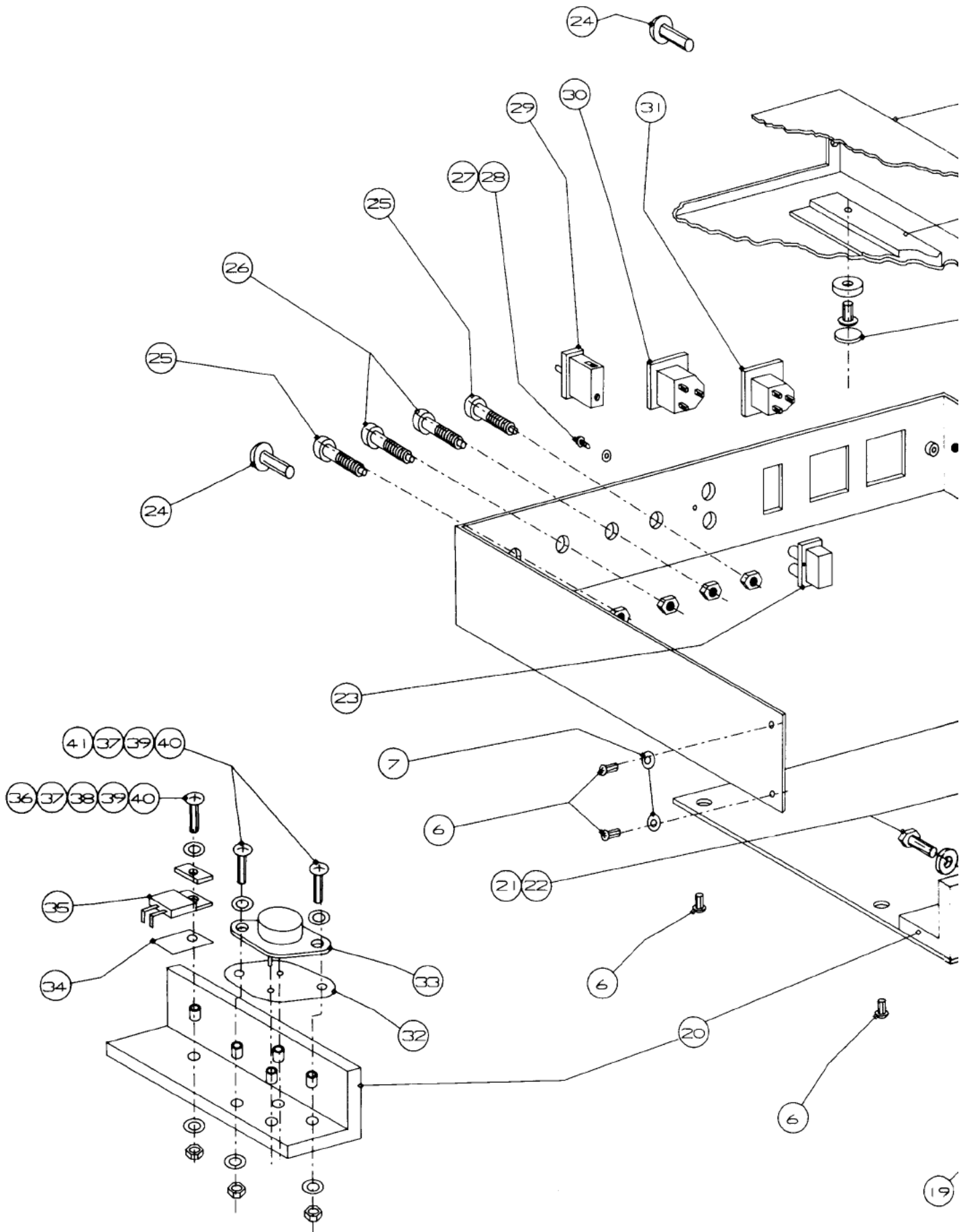
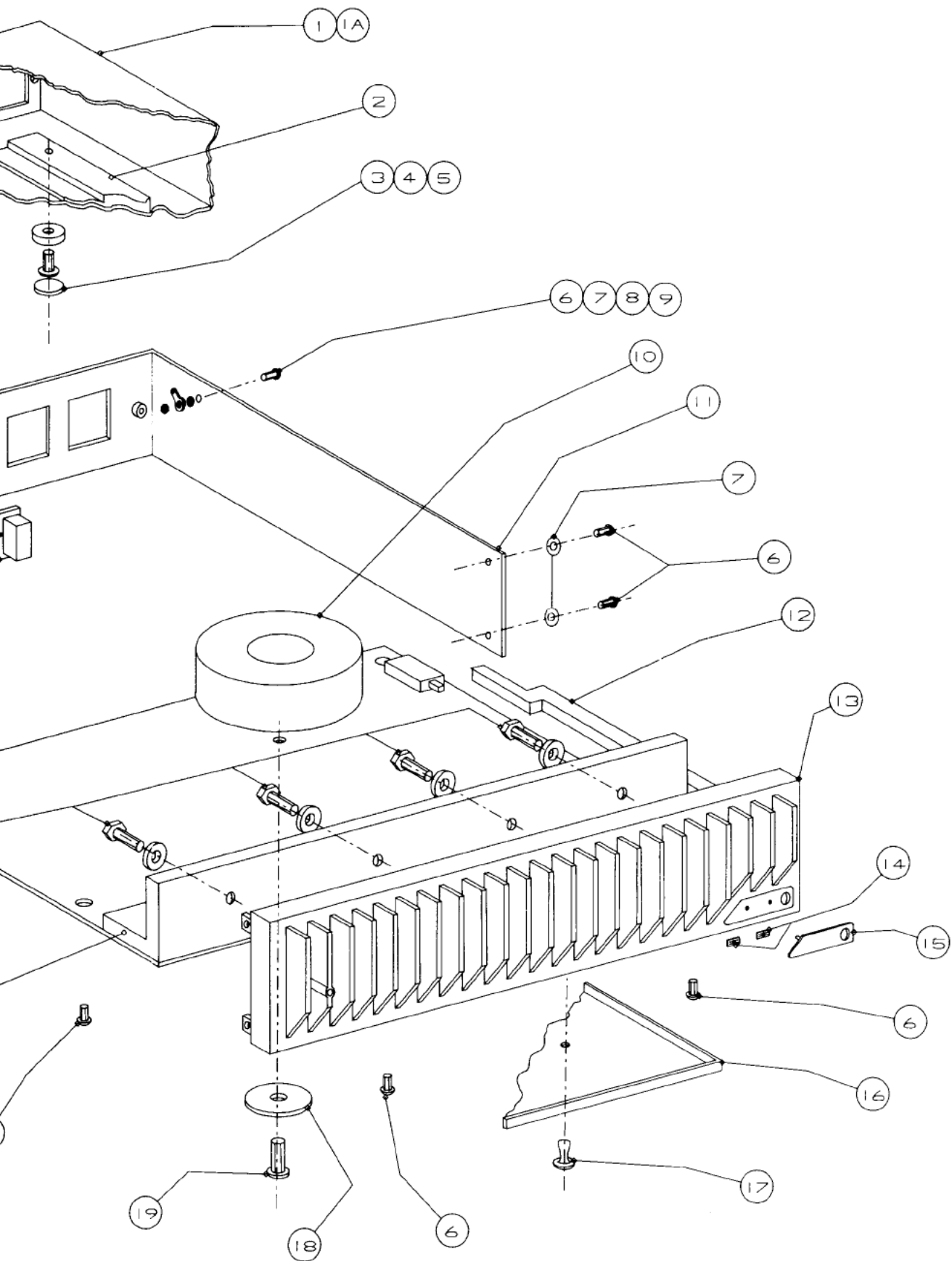

Fig 1 Exploded View



Q U A D 306 service data

PARTS LIST

ORDERING SPARE PARTS

To allow for modifications etc. please quote component reference, value and description as well as the part number, when ordering spares. Also product model and serial number.

MECHANICAL PARTS (SEE EXPLODED VIEW)

Ref.	Description	Qty	Part No.
1	Cover Complete (inc. items 1, 1A, 2, 3, 4 & 5) Grey		Q34COVG
1	Cover Only Grey		M12573G
1A	Permanite Damping Pad – Self Adhesive	2	IPEDAMA
2	Chassis Guide	2	M12562A
3	Rubber Foot Insert	4	M20172A
4	Screw M4 x 5 Pos. Pan. STL	4	TM405PB
5	Foot Moulding Black	4	M12620B
6	Screw M3 x 6 Sup. Pan. STL BZP	9	TM306PA
7	Washer M3 Shakeproof STL	5	TDM3NLA
8	Solder Tag M3		FTM331A
9	Nut M3 Full Hex STL BZP		TM3FHPA
10	Mains Transformer 220-240V (L4)*		L20571A
11	Chassis 240V		M30CHEG
-	Chassis 120V		M30CHAG
-	Chassis 100V Japan		M30CHJG
-	Chassis SEMKO		M30CHSG
12	On/Off Switch Link Grey		M12771B
13	Heatsink Ribbed Grey		M12823G
14	Spire Clip	2	FF2147A
15	Quad Nameplate		M30NP1G
16	Mains Safety Cover		M20651A
	<i>*See Main Parts List for other voltage range part numbers.</i>		

Q U A D 306 service data

Ref.	Description	Qty	Part No.
17	Cover Retaining Stud		FP70271
18	Washer M5 x 50 x 1.4 STL		M12899A
19	Screw M5 x 20 Sup Pan STL BZP		TM520PA
20	Mounting Bracket/Heatsink		M12880A
21	Bolt M4 x 6 HEX. HD/Slot BZP STL	4	TM406LA
22	Washer M4.4 x 12.5 x 0.8	4	TDM4NPA
23	Phono Sockets 2-Way PCB Mount (SK1)		PS0129A
24	Screw M4 x 16 Pos. Flange BZP	2	TX416FA
25	Output Socket Red 4mm (inc. Fixing Nut) (SK2)	2	PSRS14C
26	Output Socket Black 4mm (inc. Fixing Nut) (SK3)	2	PSBS14C
27	Drive Screw No 4 x $\frac{3}{8}$ AB		TC410PF
28	Washer M3 x 5.9 x 0.6 Steel Black		TDB6SPF
29	Circuit Breaker 0.5A 220-240V (N1)*		SP306AA
30	Mains Output Socket Euro-moated (SK4)		PSP695S
31	Mains Input Plug/Fuseholder (PL1)		PPF333C
32	Transistor Washer SIL T03	4	IWTO3XX
33	Transistor 17556 (T9, 10)	4	D17556X
34	Transistor Washer SIL TO 220	4	IWTO220
35	Transistor 40872 (T7, T8)	4	D40872X
36	Screw M3 x 16 Pan STL BZP	4	TM316PA
37	Belleville Spring Washer CW73206	24	TD73206
38	Metal Heatsink Washer TO220	4	DNR231A
39	Nylon Bush 5mm	20	M12577C
40	Nut M3 Full Hex STL BZP	12	TM3FHPA
41	Screw M3 x 14 Sup Pan STL BZP	8	TM314PA
*See Main Parts List for other voltage range part numbers.			

Q U A D 306 service data

RESISTORS

Ref.	Description				Qty	Part No.
R1	560 Ω	5%	0.25W	Carbon Film		R560RJ4
R2	22k Ω	5%	0.25W	Carbon Film		R22K0J4
R3	3k3 Ω	5%	0.5W	Carbon Film		R3K30J2
R4	3k3 Ω	5%	0.5W	Carbon Film		R3K30J2
R5	3k3 Ω	5%	0.5W	Carbon Film		R3K30J2
R6	120k Ω	5%	0.25W	Carbon Film		R120KJ4
R7	22k Ω	5%	0.25W	Carbon Film		R22K0J4
R9	33 Ω	5%	0.25W	Carbon Film		R33R0J4
R10	3k3 Ω	5%	0.5W	Carbon Film		R3K30J2
R11	47 Ω	5%	0.25W	Carbon Film		R47R0J4
R12	330 Ω	5%	0.25W	Carbon Film		R330RJ4
R13	9R1 Ω	1%	0.25W	Metal Film		R9R10F4
R14	330 Ω	5%	0.25W	Carbon Film		R330RJ4
R14A	1k Ω	5%	0.25W	Carbon Film		R1K00J4
R15	3k3 Ω	5%	0.5W	Carbon Film		R3K30J2
R16	330 Ω	5%	0.25W	Carbon Film		R330RJ4
R17	560 Ω	5%	2.5W	X2B Wirewound		R560RJO
R18	560 Ω	5%	2.5W	X2B Wirewound		R560RJO
R19	0R1 Ω	5%	2.5W	CB3		R0R10JC
R20	22 Ω	5%	0.25W	Carbon Film		R22R0J4
R21	22 Ω	5%	0.25W	Carbon Film		R22R0J4
R22	560 Ω	2%	2.5W	TFP3		R560RGC
R23	0R1 Ω	5%	2.5W	CB3		R0R10JC
R23A	0R3 Ω	5%	2.5W	FCA2		R0R30JX
R24	22 Ω	5%	0.25W	Carbon Film		R22R0J4
R25	22 Ω	5%	0.25W	Carbon Film		R22R0J4

QUAD 306 service data

Ref.	Description				Qty	Part No.
R26	10 Ω	5%	0.5W	Carbon Film		R10R0J2
R27	12k Ω	5%	1.6W	Metal Film		R12K0JR
R28	10k Ω	1%	0.25W	Metal Film		R10K0F4
R29	9k1 Ω	1%	0.25W	Metal Film		R9K10F4
R30	2k2 Ω	5%	0.25W	Carbon Film		R2K20J4
R31	2k2 Ω	5%	0.25W	Carbon Film		R2K20J4
R32	10 Ω	5%	0.5W	Carbon Film		R10R0J2
R33	2M2 Ω	5%	0.25W	Carbon Film		R2M20J4
R34	10k Ω	5%	0.25W	Carbon Film		R10K0J4
R35	10k Ω	5%	0.25W	Carbon Film		R10K0J4

CAPACITORS

C1	330pf	10%	50V	UP125		C330PKJ
C2	100nF	10%	250V			C100NKE
C3	680nF	10%	63V			C680NKA
C4	180pF	10%	50V	UP125		C180PKJ
C5	330pF	10%	50V	UP125		C330PKJ
C6	330pF	10%	50V	UP125		C330PKJ
C7	47 μ F	20%	63V			C47U0MM
C8	47pF	1%	350V	Silver Mica		C47P0FS
C9	47nF	5%	250V			C47N0JS
C10	4700 μ F	20%	50V			C4K7UMA
C11	4700 μ F	20%	50V			C4K7UMA
C12	4n7F	10%	50V	UP125		C4N70SJ

Q U A D 306 service data

SEMICONDUCTORS

Ref.	Description	Qty	Part No.
T1	Transistor BC214C		DBC214C
T2	Transistor MPSA-43-K		DMPSA43
T3	Transistor BC413C		DBC413X
T4	Transistor MPSA93-K		DMPSA93
T5	Transistor MPSA93-K		DMPSA93
T6	Transistor MPSA93-K		DMPSA93
T7	Transistor 40872-99		D40872X
T8	Transistor 40872-99		D40872X
T9	Transistor 17556		D17556X
T10	Transistor 17556		D17556X
T11	Transistor ZTX650-K		DZTX650
T12	Transistor ZTX750-K		DZTX750
D1	Diode Zener 6V8 500MW		D886V8A
D2	Diode Zener 6V8 500MW		D886V8A
D3	Diode Zener 6V8 500MW		D886V8A
D4	Diode Zener 6V8 500MW		D886V8A
D5	Diode 1N4003 1A 200V		D1N4003
D6	Diode 1N4003 1A 200V		D1N4003
D7	Diode 1N4003 1A 200V		D1N4003
D8	Diode 1N4003 1A 200V		D1N4003
D9	Diode 1N4003 1A 200V		D1N4003
D10	Diode 1N4003 1A 200V		D1N4003
D11	Diode LED T1 Green 3mm Dia		BLG124T
D12	Bridge Rectifier BY225-100		DBY225X
D13	Diode 1N4148		D1N414R
CR1	Current Source LM334Z		DLM334Z
CR2	Diode Current Regulator J503		DJ503XX
IC1	Integrated Circuit TLC271 CP		DTLC271

QUAD 306 service data

MISCELLANEOUS

Ref.	Description	Qty	Part No.
L1	Choke 20 μ H		L12861A
L2	Choke 6 μ 9H		L12406A
L3	Choke 1 μ 5H 5%		L00582A
L4	Mains Transformer 200-240V		L20571A
-	Mains Transformer 110-120V		L12905A
-	Mains Transformer 120V (CSA)		L12905C
-	Mains Transformer 100V (Japan)		L12916A
N1	Circuit Breaker 0.5A 220-240V		SP306AA
-	Circuit Breaker 1A 110-120V (CSA)		SP306AB
-	Circuit Breaker 1.5A (Japan)		SP306AJ
FS1	Mains Fuse 2AT 20mm 220-240V		UM02ADA
-	Mains Fuse 3.15AT 20mm 110-120V (Japan)		UM3A15D
-	Mains Fuse 3AT 20mm 120V (CSA)		UM03ADC
PL1	Mains Input Plug/Fuseholder - Euro		PPF333C
SK1	Phono Sockets 2-way PCB Mount		PS0129A
SK2	Output Socket Red 4mm (inc. Fixing Nut)	2	PSRS14C
SK3	Output Socket Black 4mm (inc. Fixing Nut)	2	PSBS14C
SK4	Mains Output Socket - Euro Moated		PSP695S
S1	Mains Switch ALPS SDS3P		SF4OFFA

ACCESSORIES

1	Speaker Plug Red 4mm	2	PP60912
2	Speaker Plug Black 4mm	2	PP60920
3	Signal Lead 1m 2 phono - 2 phono		QP2P21A
4	Mains Lead 1m IEC Plug Shrouded-IEC Socket		QSPES1B
5	19" Panel for Rack Mounting		M20341A
6	Instruction Book (English)		OI301EC

Q U A D 306 service data

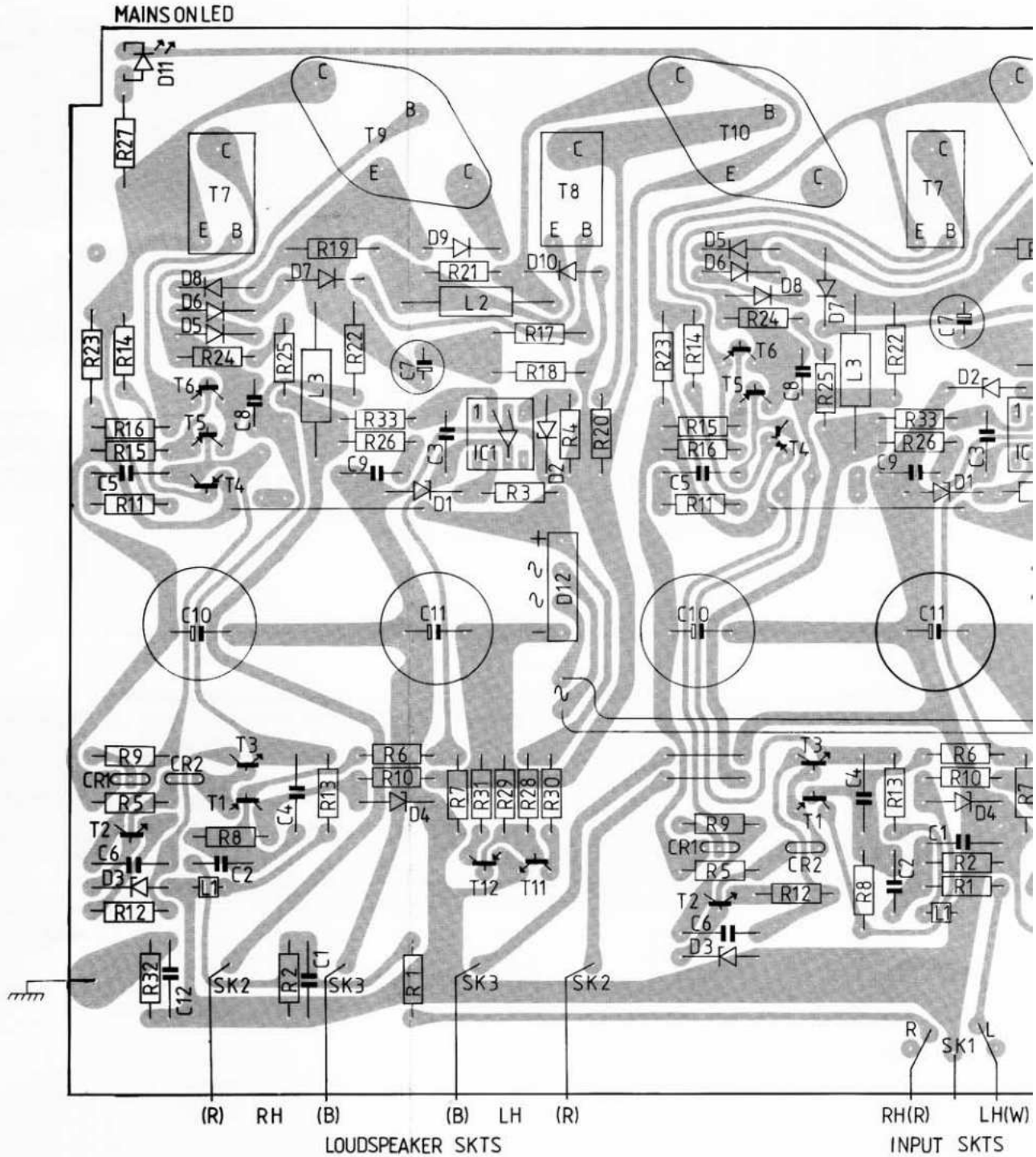

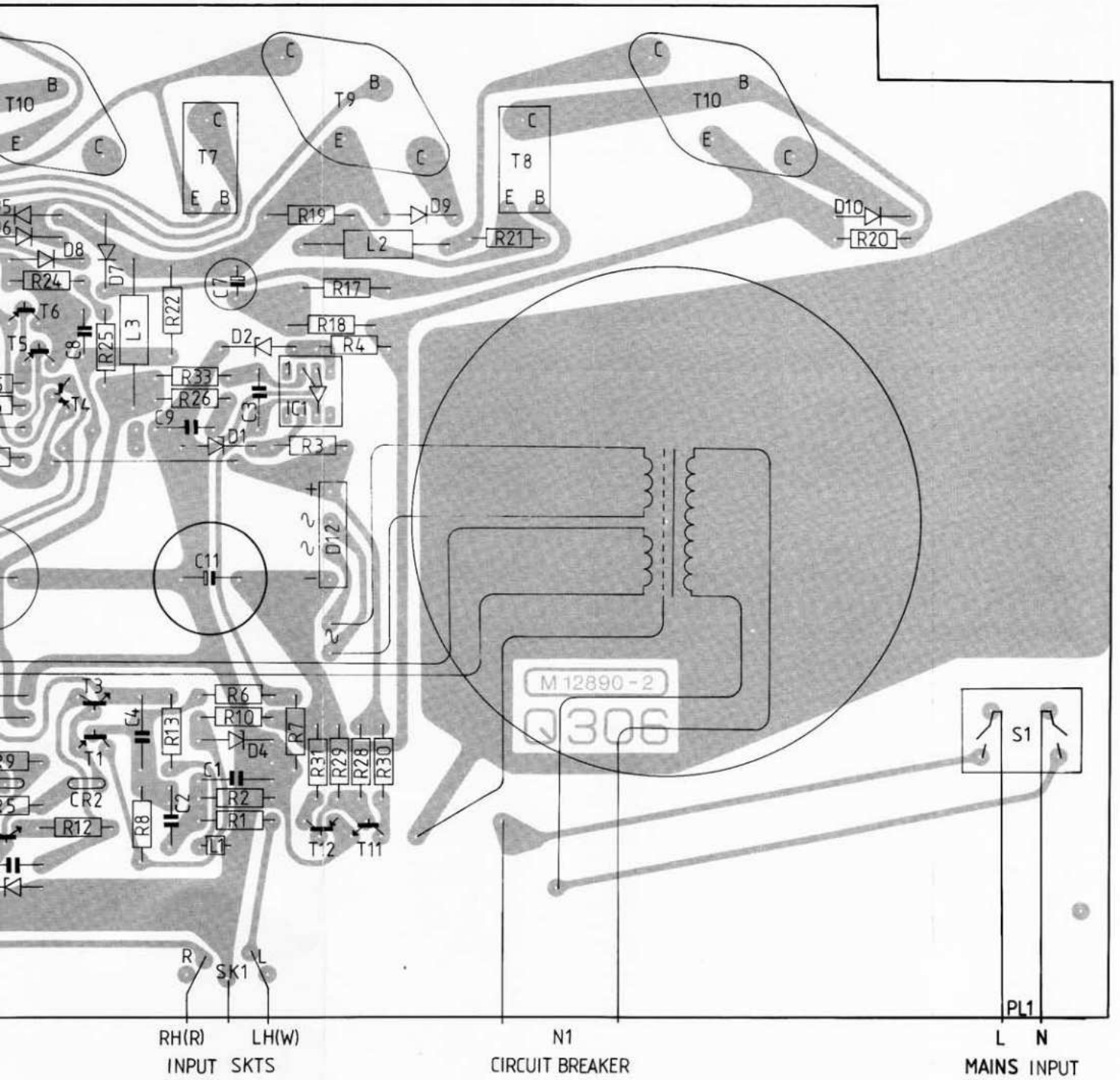

SOME MODELS HAD R14A BETWEEN T4 BASE EMITTER. TO COMPENSATE FOR TOLERANCES IN OUTPUT DEVICES. ALTERNATIVELY R23A MAY BE FITTED ACROSS R23.

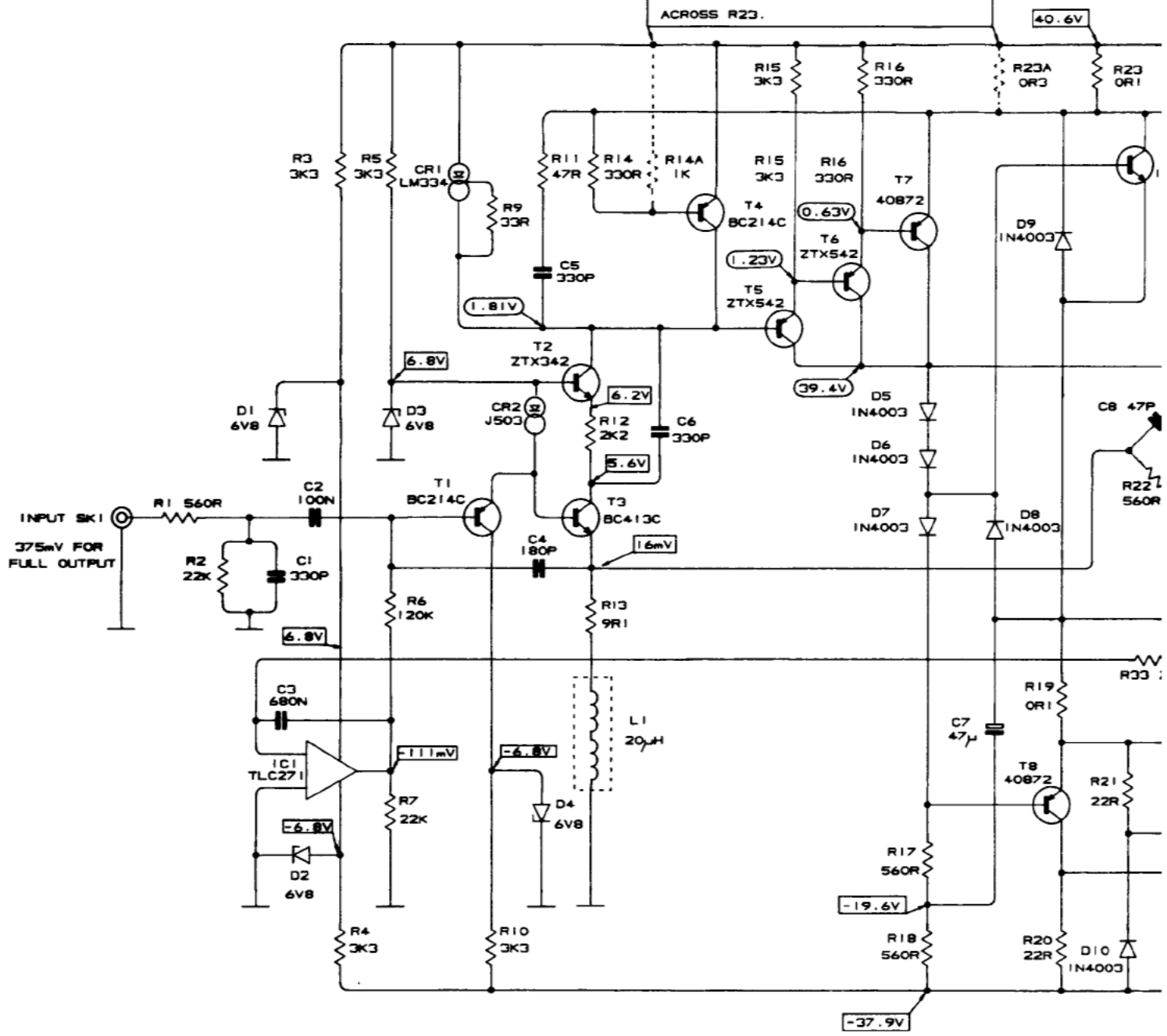

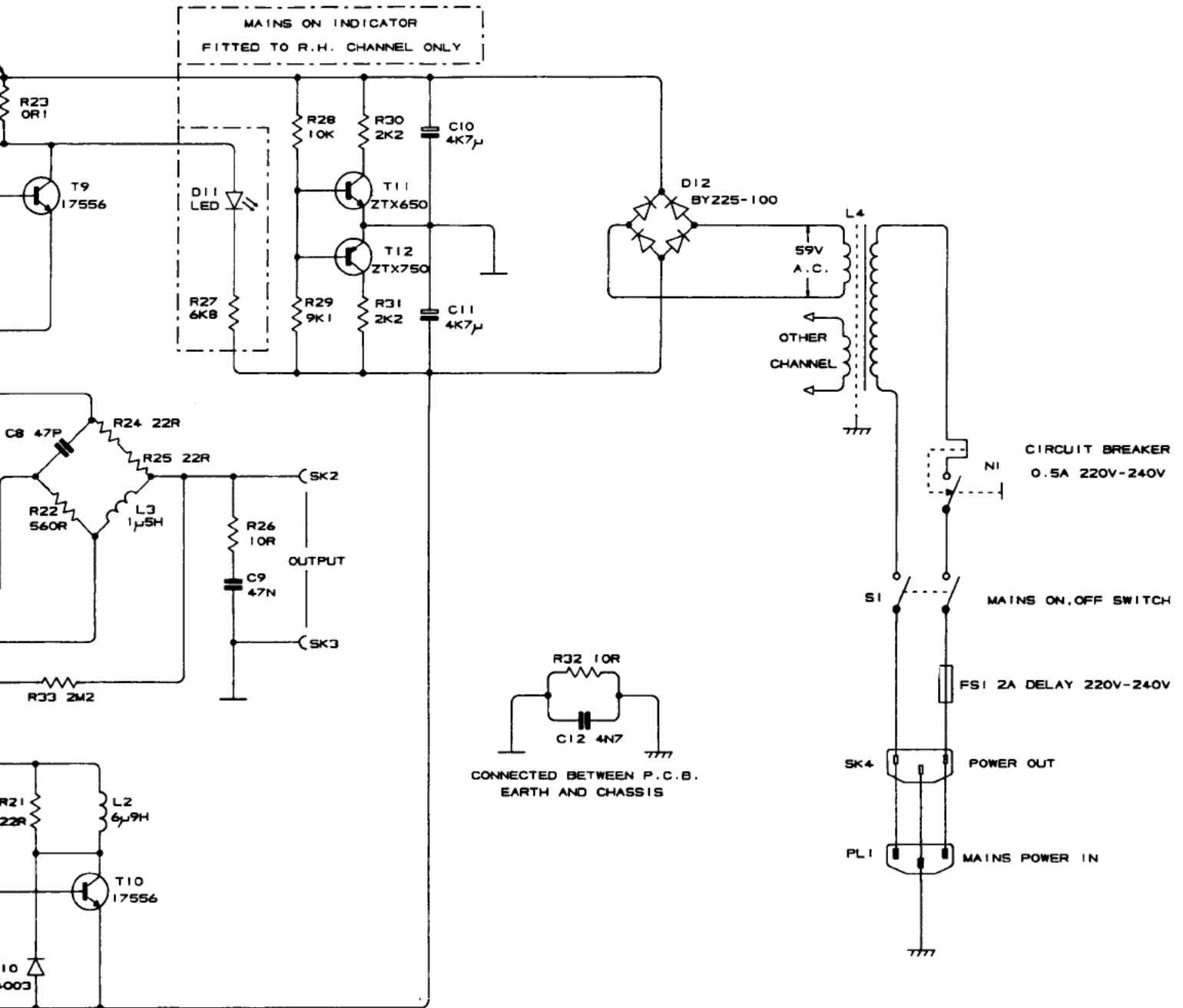

Q U A D 306 service data



P.C.B. BRD. No M12890-2

VOLTAGE MEASUREMENTS

ALL VOLTAGE MEASUREMENTS ARE TYPICAL AND WERE TAKEN WITH A MAINS SUPPLY OF 240V USING A THURLBY 1504 DIGITAL METER, WITH NO INPUT SIGNAL

-  MEASURED USING -VE PROBE W.R.T. THE +VE RAIL
-  MEASURED USING +VE PROBE W.R.T. P.C.B. EARTH

Circuit Diagram (Issue 2 PCB)

MAISON LED

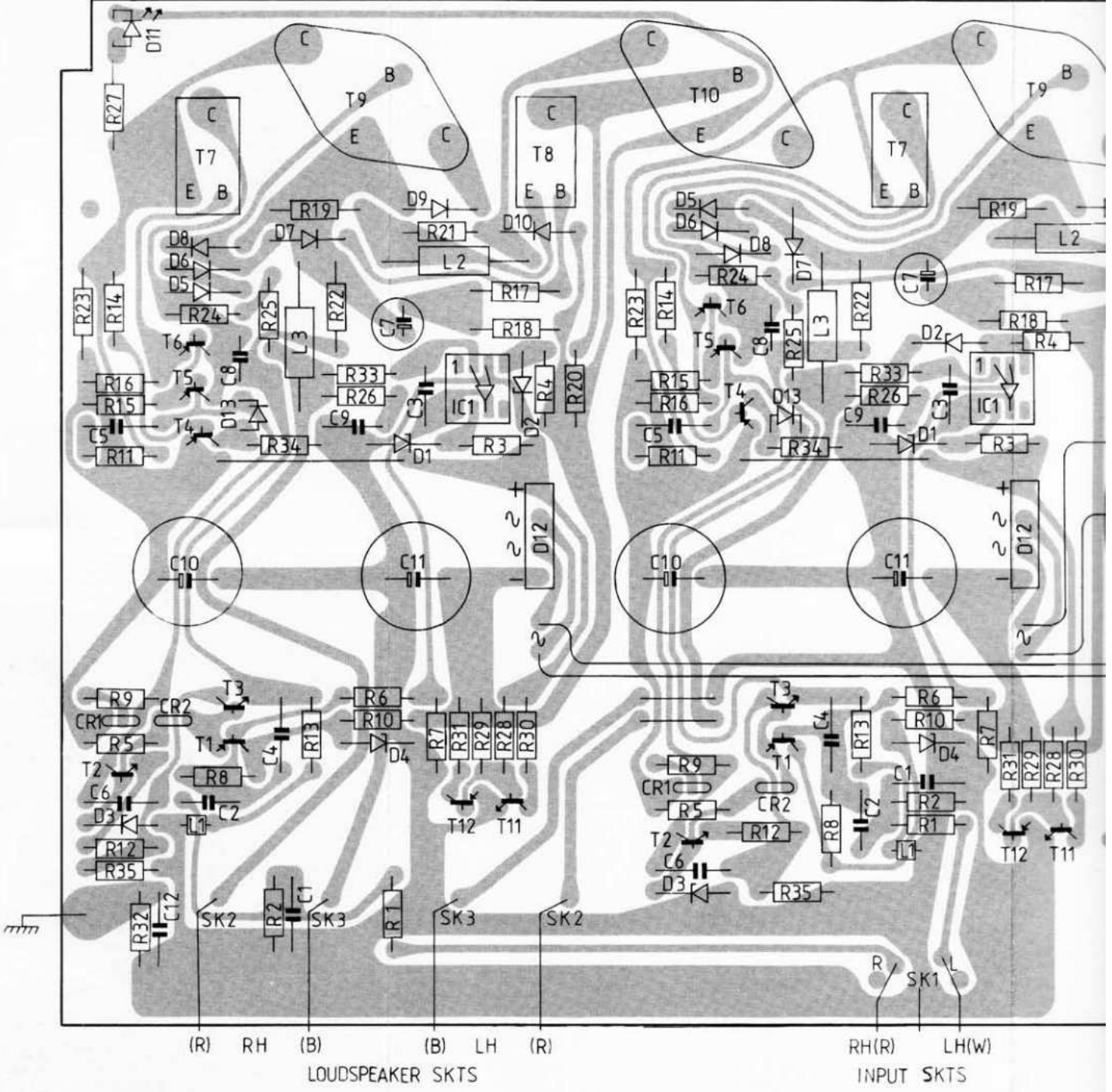

Q U A D 306 service data

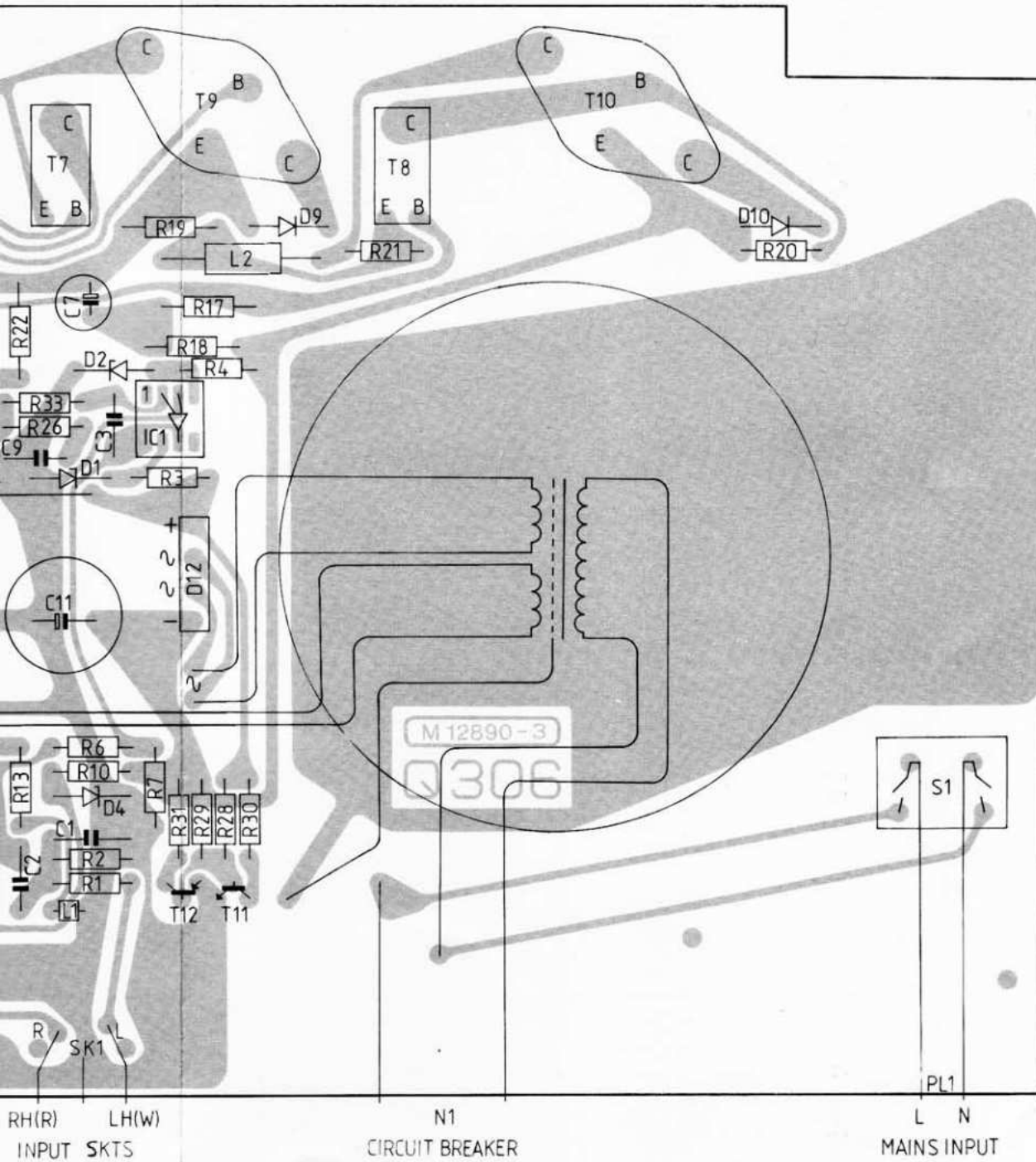

PCB Layout (Issue 3 PCB) Track Side

R11 ORIGINALLY CONNECTED TO R14 RAIL
ON LATER VERSIONS R11 CONNECTED TO
MAIN +VE RAIL AND MOUNTED ON BACK
OF PCB.

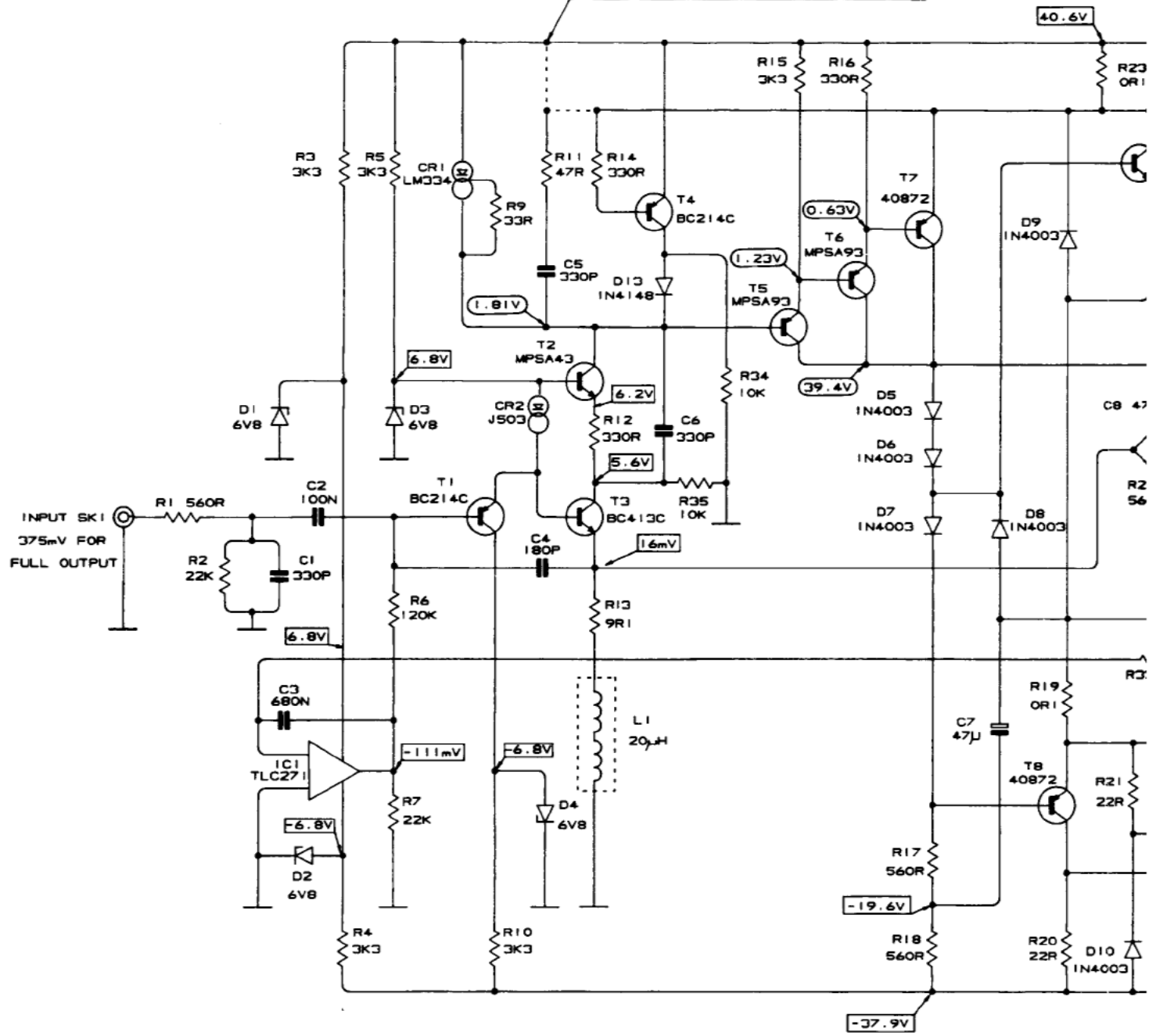

Q U A D 306 service data

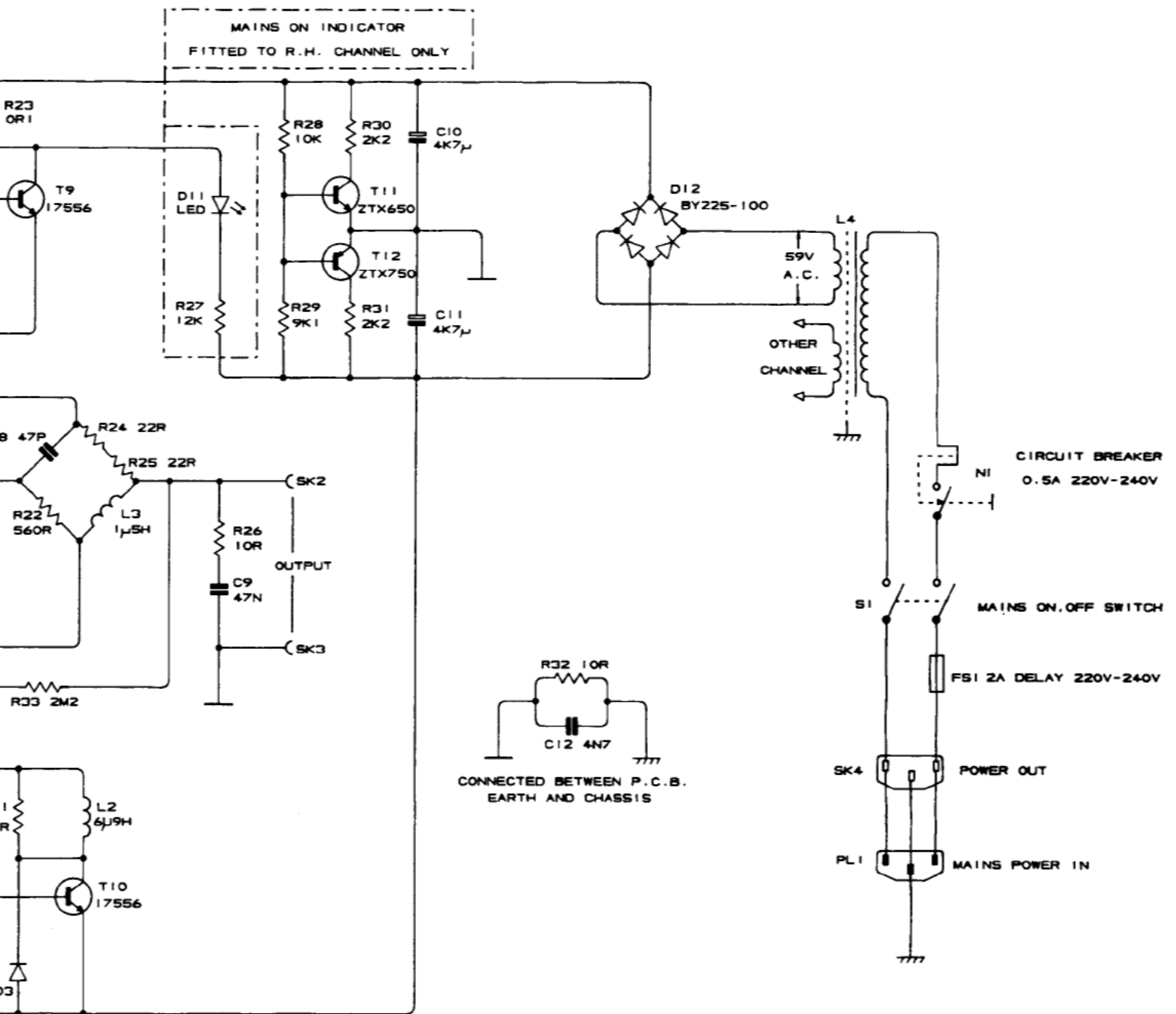

P.C.B. BRD. No M12890-3

VOLTAGE MEASUREMENTS

ALL VOLTAGE MEASUREMENTS ARE TYPICAL AND WERE TAKEN WITH A MAINS SUPPLY OF 240V USING A THURLBY 1504 DIGITAL METER, WITH NO INPUT SIGNAL

- MEASURED USING -VE PROBE W.R.T. THE +VE RAIL
- MEASURED USING +VE PROBE W.R.T. P.C.B. EARTH

Circuit Diagram (Issue 3 PCB)